

FRONT VIEW 1:1

SIDE VIEW landscape10:1

BACK VIEW 1:1

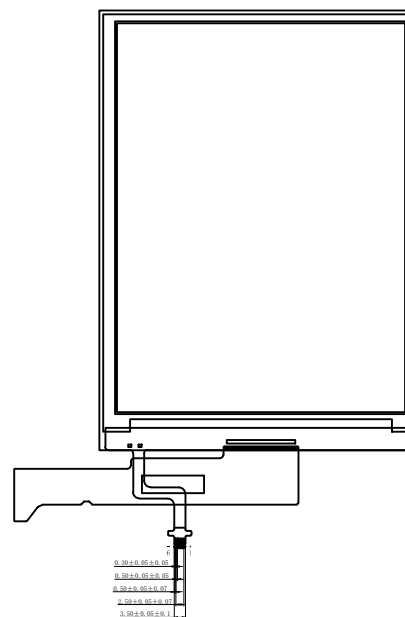
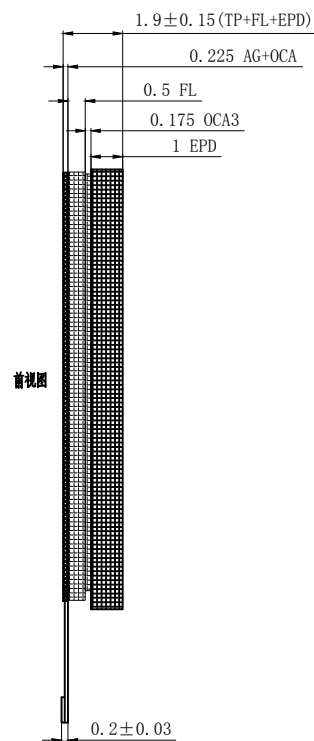
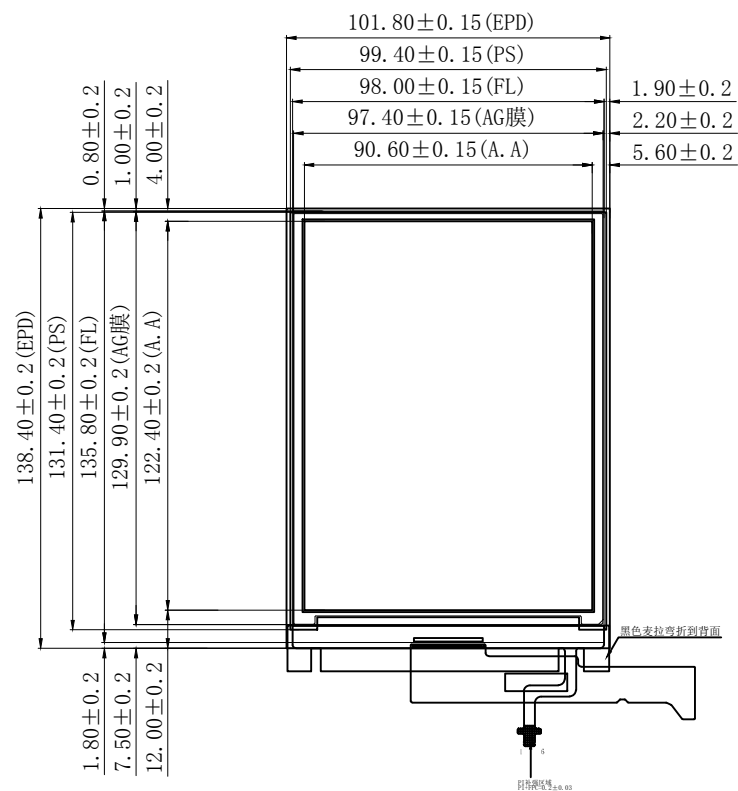

Technical Parameters:

1. Full Fitting Process
2. Working Voltage: 2.8V~3.6 V
3. Luminousness: $\geq 83\%$
4. Surface Hardness: $\geq 2H$
5. Operating Environment: $0^{\circ}\text{C} \sim +45^{\circ}\text{C}$, $\leq 90\% \text{RH}$
6. Storage Environment: $20^{\circ}\text{C} \sim +24^{\circ}\text{C}$, $40\% \text{RH} \sim 70\% \text{RH}$
7. Unlabeled Tolerance: $\pm 0.2 \text{mm}$

DALIAN GOOD DISPLAY CO., LTD.

DRAWN BY:	PRODUCT MODEL: FRONTLIGHT DRAWING FOR GDE060BA	VIEW:
CHECKED BY:	CUSTOMER ID:	
APPROVED BY:	DATE: 2017-08-18	UNITS mm
Standard tolerance:	WEBSITE: www.good-display.com	SCALE 1:1