



4.3 inch E-paper Display Series



GDE043A2

Dalian Good Display Co., Ltd.

Product Specifications

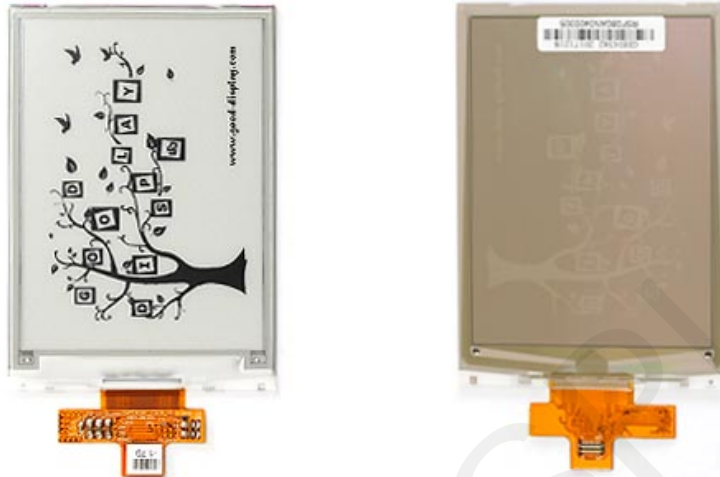

Customer	Standard
Description	4.3" E-PAPER DISPLAY
Model Name	GDE043A2
Date	2019/01/08
Revision	2.0

	Design Engineering		
	Approval	Check	Design
			

No.17 Gonghua Street, Shahekou District, Dalian 116021 China

Tel: +86-411-84619565 Fax: +86-411-84619585-810

Email: info@good-display.com

Website: www.e-paper-display.com

Contents

1. General Description	5
2. Features.....	5
3. Application	5
4. Pin Assignment.	6
5. Eletrical Characteristics	7
6. Power On Sequence	10
7. Mechanical Characteristics	11
8. Optical Specification	13
9. Handling, Safety, and Enviromental Requirements	14
10. Reliability Testing.....	15
11. Block Diagram	16
12. Packaging	17
13. Precautions	18

Version	Content	Date	Producer
1.0	New release	2012.08.24	
2.0	Updating	2019.01.08	

GOOD DISPLAY

1. General Description

GDE043A2 is an Active Matrix Electrophoretic Display(AM EPD), High-Resolution AM TFT Black/White display module can be used in portable electronic devices, such as E-book Reader.

The module is a TFT-array driving electrophoretic display, with integrated circuits including source and gate drivers. The resolution of the module is 800×600 (SVGA) , and the active area is 4.3 inch diagonal.

2. Features

- ◆ 800×600 display
- ◆ White Reflectance above 35%
- ◆ Contrast Ratio above 8:1
- ◆ 4:3 aspect ratio
- ◆ 230 dpi
- ◆ Wide viewing angle
- ◆ Ultra low power consumption
- ◆ Reflective mode
- ◆ Bi -stable display
- ◆ Commercial temperature range
- ◆ Landscape, portrait modes
- ◆ Hard-coat antiglare display surface
- ◆ Parallel Interface

3. Application

E-book reader.

Smart home products.

4. Input/output pin assignment

1	VNEG	Negative power supply source driver
2	VPOS	Positive power supply source driver
3	VSS	Ground
4	VDD	Digital power supply drivers
5	CLK	Clock source driver
6	LE	Latch enable source driver
7	OE	Output enable source driver
8	SHR	Shift direction source driver
9	SPH	Start pulse source driver
10	D0	Data signal source driver
11	D1	Data signal source driver
12	D2	Data signal source driver
13	D3	Data signal source driver
14	D4	Data signal source driver
15	D5	Data signal source driver
16	D6	Data signal source driver
17	D7	Data signal source driver
18	VCOM	Common connection
19	VGH	Positive power supply gate driver
20	VGL	Negative power supply gate driver
21	GMODE2	Output mode selection gate driver (H)
22	GMODE1	Output mode selection gate driver (H)
23	L/R	Shift direction gate driver
24	STV	Start pulse gate driver
25	CPV	Shift clock input
26	VBORDER	Border connection

5. Electrical Characteristics

5.1 Module interface description

This module can be driven by ASIC AVT6201A Timing Controller(T-Con).

5.2 Module DC characteristics

Parameter	Symbol	Conditions	Min	Typ	Max	Unit
Signal ground	VSS		-	0	-	V
Logic Voltage supply	VDD		3.0	3.3	3.6	V
	IVDD	VDD=3.3V		-		uA
Gate Positive supply	VGH		7	-	VGL+42	V
	IVGH			100		uA
Gate Negative supply	VGL		-25	-	-5	V
	IVGL			100		uA
Source Positive supply	VPOS		-0.3	15	20	V
	INEG	VPOS=-15V	-	14	-	mA
Source Negative supply	VNEG		-16	-15	-10	V
	IPOS	VNEG=15V		-14		mA
Asymmetry source	VASYM	VPOS+VNEG	-80	0	80	mV
Common voltage	VCOM		-2.5	Adjusted	0	V
	ICOM		-	0.8	-	mA
Standby power module	PSTBY			-	0.26	mW
Typical power module	PTYP		-	260	800	mW
Operating temperature			0		50	°C
Storage temperature			-20	-	70	°C
Humidity range	-		40	-	70	%RH
Maximum image update time at 25°C				960	1200	ms

Notes:

1. The maximum power and maximum current are specified for the worst case power consumption.
2. The typical power is measured when "typical images" are displayed.
3. The standby power is the consumed power when the module controller is in standby mode.
4. The listed electrical/optical characteristics are only guaranteed under the controller & waveform provided by Good Display.

5.3 Module AC characteristics

Note: VDD=3.0V to 3.6V, unless otherwise specified

Parameter	Symbol	Min.	Typ.	Max.	Unit	App Pin
Clock frequency	fcpv			200	kHz	CPV
Clock CPV high time	tCPVh	0.5	-	-	us	
Clock CPV low time	tCPVl	0.5	-	-	us	
Data setup time	tSU	100	-	-	ns	CPV STV
Data hold time	tH	300	-	-	ns	
Clock CLK cycle time	tclk	40	-	-	ns	Below table
D0 .. D7, SPH setup time	tsu	8	-	-	ns	
D0 .. D7, SPH hold time	th	8	-	-	ns	
LE on delay time	tLEdly	40	-	-	ns	
LE high-level pulse width	tLEw	40	-	-	ns	
LE off delay time	tLEoff	40	-	-	ns	
SHR setup time	tMsu	100	-	-	ns	
SHR hold time	tMh	10	-	-	ns	

Clock & Data Timing

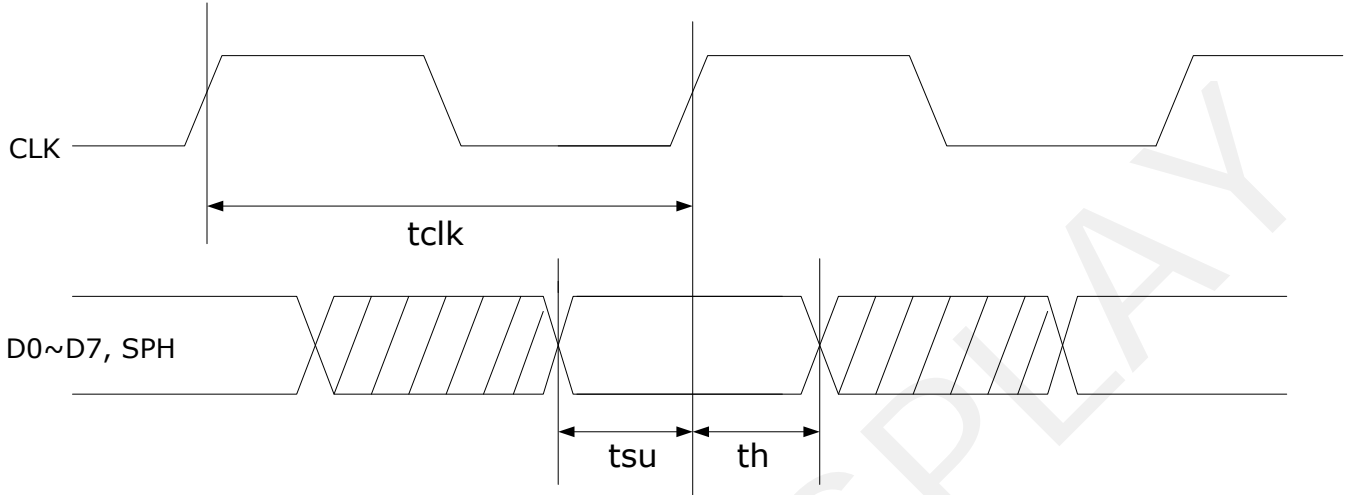

Output Latch/Control Signals

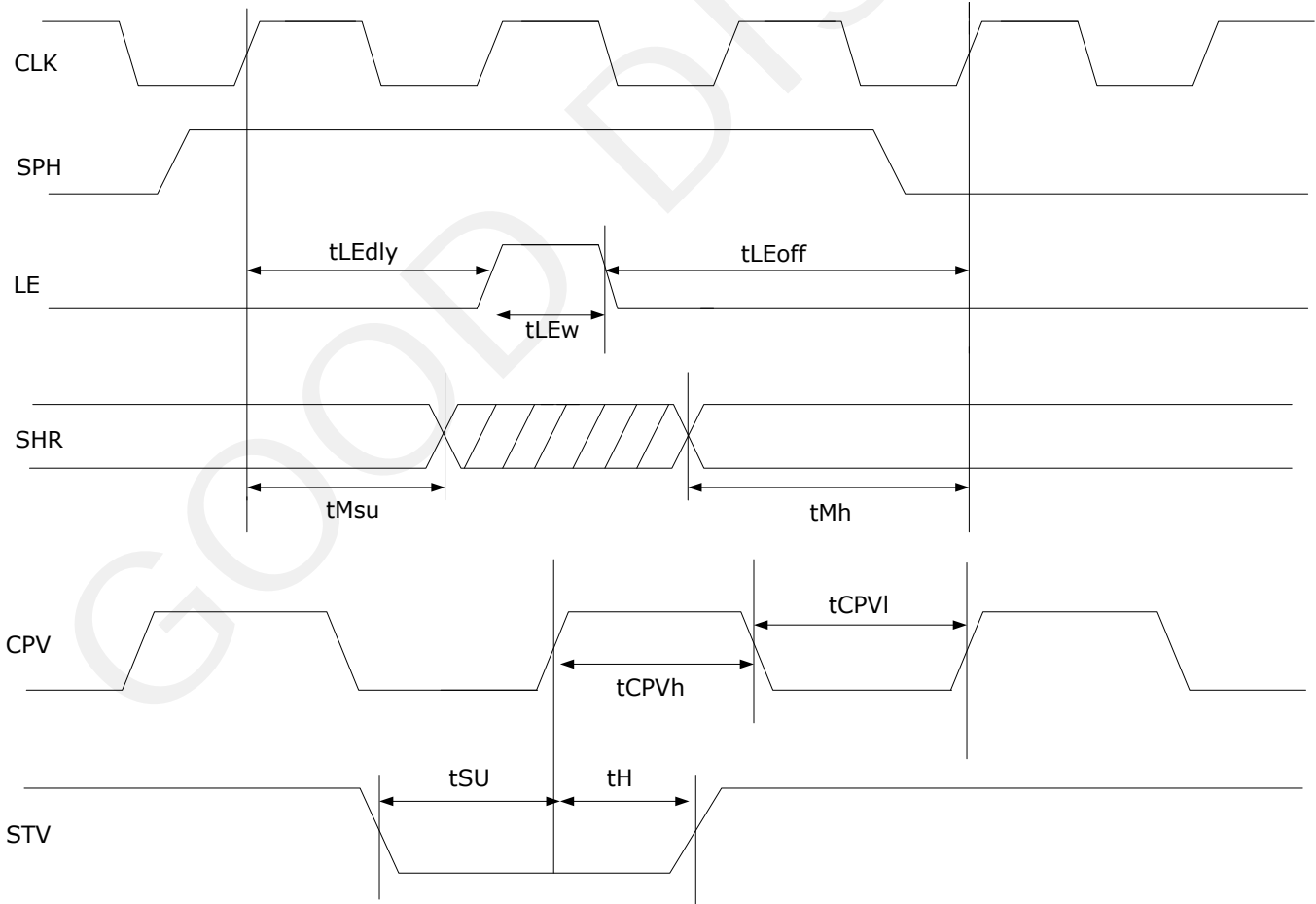

6. Power On Sequence

VDD -> VNEG -> VPOS (Source Driver)

VGL -> VGH (Gate Driver)

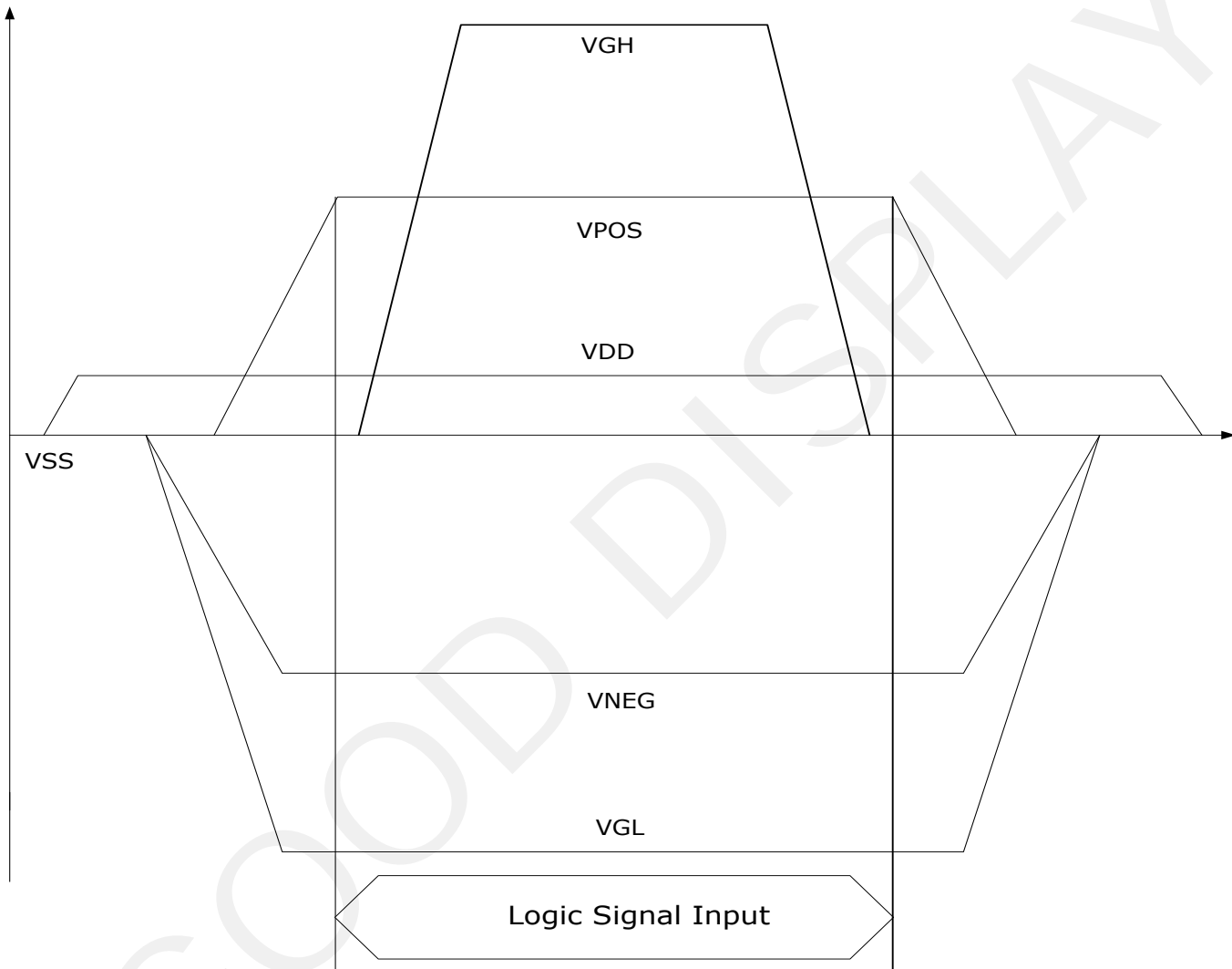

7. Mechanical Specification

7.1 Dimension

PARAMETER	VALUE	UNIT	Remark
Display Resolution	800×600	dots	
Active area dimensions Width Height	88 66	mm mm	
Screen size	4.3 (4:3 diagonal)	Inch	
Resolution	230	dpi	
Pixel pitch Horizontal Vertical	0.11 0.11	mm mm	
Pixel configuration	Rectangle		
Overall dimensions Width Height Thickness	126.5 74.6 1.17	mm mm mm	
Mass of the module	19±0.5	g	

7.2 Electrical Connector

SERVICE	CONNECTOR	TYPE NUMBER	NUMBER OF PINS	MATING CONNECTOR
Interface	PANASONIC	AXT526124	26	FPC pitch=0.4mm

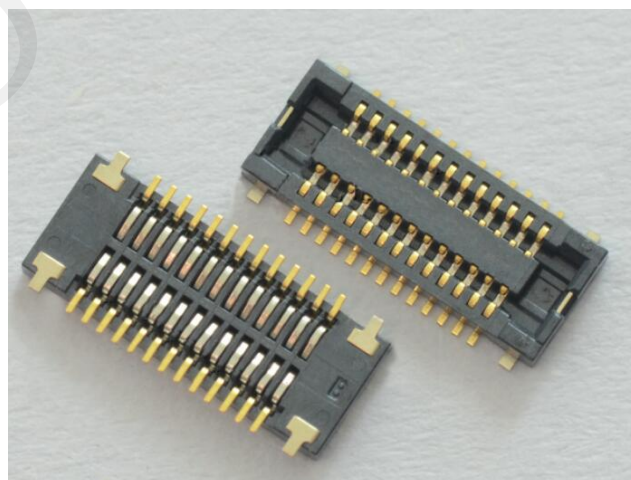

7.3 Mechanical Drawing of EPD Module

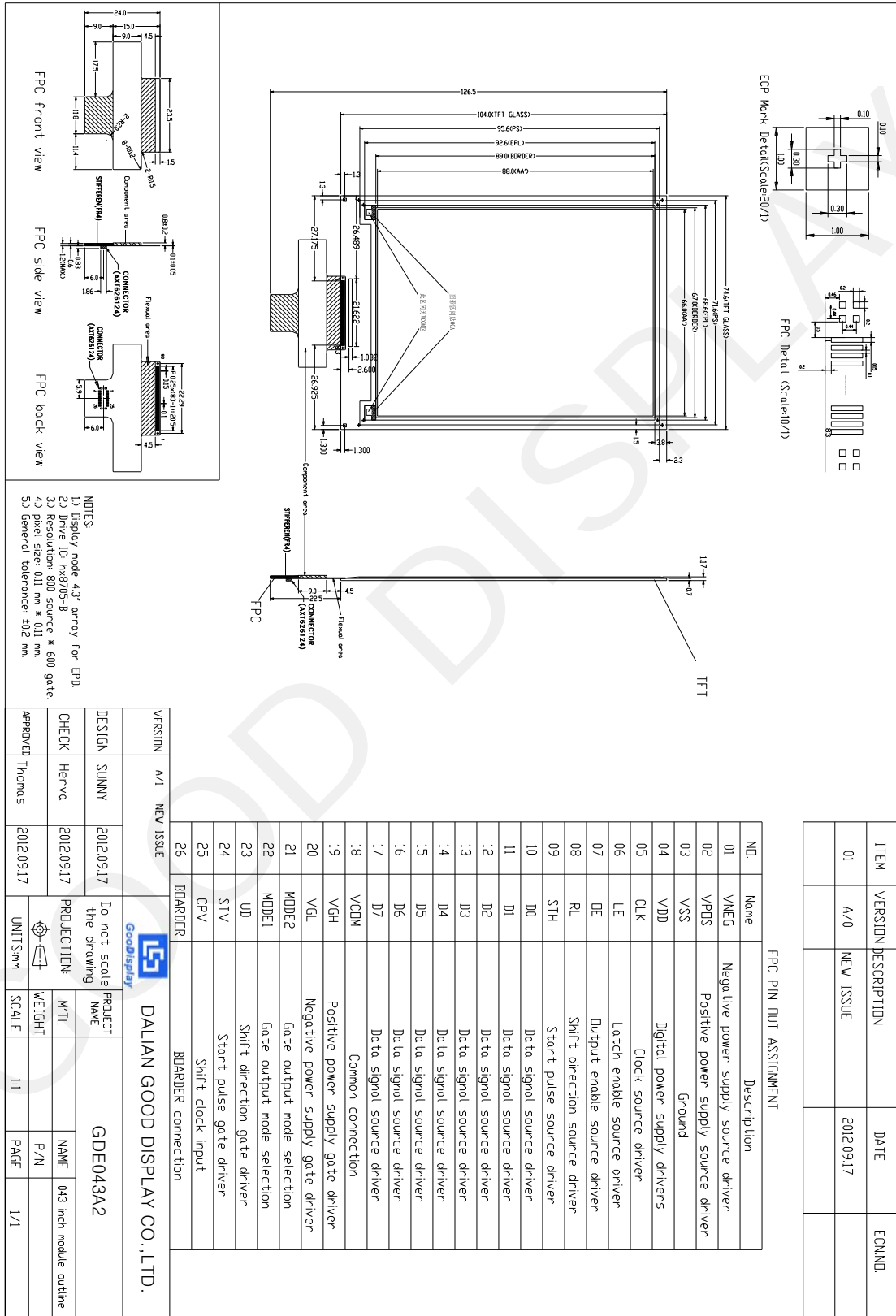

8 Optical Specification

8.1 Optical characteristics

Parameter	Conditions	Values			Units	Notes
		Min.	Typ.	Max		
White Reflectivity	White	35			%	
Contrast Ratio (CR)		8:1				1
Image Update Time:	GC16(T=0°C)		1500	1600	ms	
	GC16(T=25°C)		960	1200		
	GC16(T≥35°C)		760	960		
	DU (T=0°C)		500	540		
	DU(T≥20°C)		300	360		
Image Sticking(Ghosting)		-2.0	1.0	2.0		2

(T_{amb}=25°C, f_v=50Hz, V_{epd}= +/- 15V; supply voltage module is 3.3VDC. Measurements are made with Eye-One Pro Spectrophotometer.)

Notes:

- 1.CR=Surface Reflectance with all white pixel/Surface Reflectance with all black pixels;
- 2.Ghosting Testing:
 - 2.1 Testing Pattern

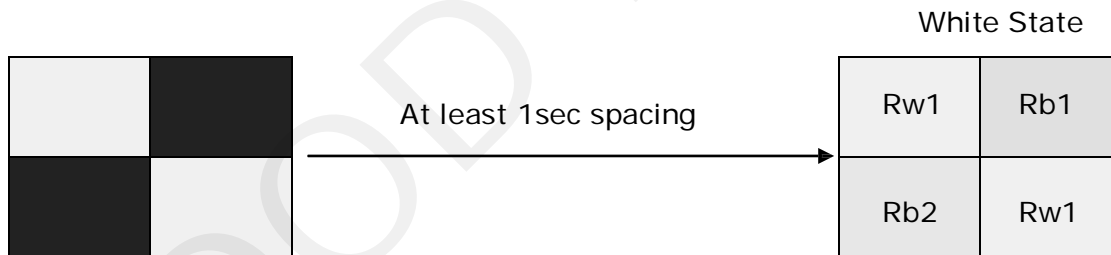

- 2.2.Refresh process: Init----GC White----4 checkerboard PatternGC) ----GC White.
- 2.3. Measuring the reflectance of all 4 checkerboard areas when final white state by Eye-one device.
- 2.4. Rw: reflectance of area transited from white state; Rb: reflectance of area transited from dark(black) state.
- 2.5. Calculating averages of WS-to-WS and DS-to-WS transitions: $Rw(ave)=(Rw1+Rw2)/2$, $Rb(ave)=(Rb1+Rb2)/2$, $G=Rw(ave)-Rb(ave)$.

9. Handling, Safety, and Environment Requirements

Warning

The display glass may break when it is dropped or bumped on a hard surface. Handle with care. Should the display break, do not touch the electrophoretic material. In case of contact with electrophoretic material, wash with water and soap.

Caution

The display module should not be exposed to harmful gases, such as acid and alkali gases, which corrode electronic components.

Disassembling the display module can cause permanent damage and invalidates the warranty agreements.

Observe general precautions that are common to handling delicate electronic components. The glass can break and front surfaces can easily be damaged. Moreover the display is sensitive to static electricity and other rough environmental conditions.

10. Reliability test

No.	TEST	CONDITION	METHOD	REMARK
1	High- Temperature Operation	T = +50°C, RH = 30% for 240 hrs	IEC 60 068-2-2Bp	At the end of the test, electrical, mechanical, and optical specifications shall be satisfied.
2	Low- Temperature Operation	T = 0°C for 240 hrs	IEC 60 068-2-2Ab	At the end of the test, electrical, mechanical, and optical specifications shall be satisfied.
3	High- Temperature Storage	T = +70°C, RH=23% for 240 hrs	IEC 60 068-2-2Bp	At the end of the test, electrical, mechanical, and optical specifications shall be satisfied.
4	Low- Temperature Storage	T = -25°C for 240 hrs	IEC 60 068-2-1Ab	At the end of the test, electrical, mechanical, and optical specifications shall be satisfied.
5	High- Temperature, High-Humidity Operation	T = +40°C, RH = 90% for 168 hrs	IEC 60 068-2-3CA	At the end of the test, electrical, mechanical, and optical specifications shall be satisfied.
6	High Temperature, High- Humidity Storage	T = +60°C, RH=80% for 168hrs	IEC 60 068-2-3CA	At the end of the test, electrical, mechanical, and optical specifications shall be satisfied.
7	Thermal Shock	1 cycle: [-25°C 30min]→ [+70°C 30 min]: 50 cycles	IEC 60 068-2-14	At the end of the test, electrical, mechanical, and optical specifications shall be satisfied.
8	Package Vibration	1.04G, Frequency: 10~500Hz Direction: X,Y,Z Duration: 1hours in each direction	Full packed for shipment	At the end of the test, electrical, mechanical, and optical specifications shall be satisfied.
9	Package Drop Impact	Drop from height of 122 cm on concrete surface. Drop sequence: 1 corner, 3edges, 6 faces One drop for each	full packed for shipment	At the end of the test, electrical, mechanical, and optical specifications shall be satisfied.
10	Electrostatic Effect (non-operating)	Machine model +/- 250V, 0Ω , 200pF	IEC 62179, IEC 62180	At the end of the test, electrical, mechanical, and optical specifications shall be satisfied.
11	Altitude test Operation	700hPa (= 3000m) 48Hr		At the end of the test, electrical, mechanical, and optical specifications shall be satisfied.
12	Altitude test Storage	260hPa (= 10000m) 48Hr		At the end of the test, electrical, mechanical, and optical specifications shall be satisfied.
13	Stylus Tapping	POLYACETAL Pen: Top R0.8mm Load: 200gf; Speed: 30time s/min; Speed: 30times/min Total 13,500times,		At the end of the test, electrical, mechanical, and optical specifications shall be satisfied.

11 Block Diagram

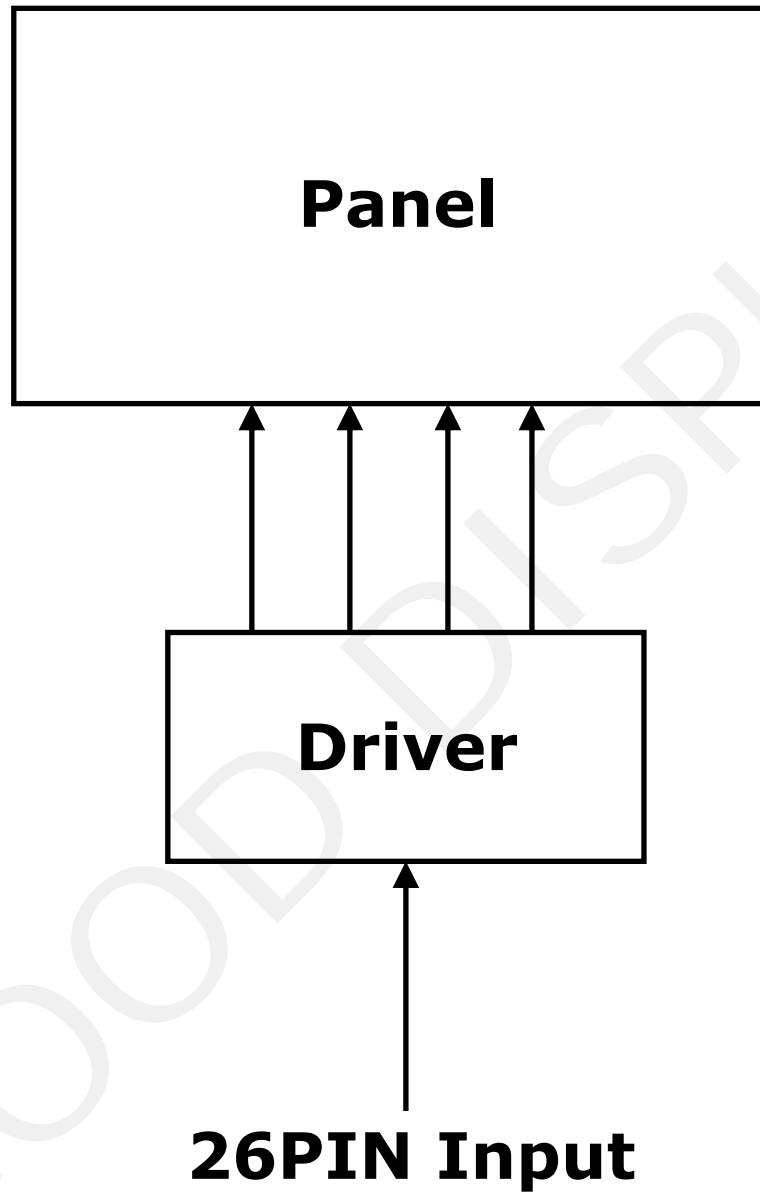

]

12 Packaging

Packing Form

- a) Package quantity in one outer box: 96 pcs
- b) box size: 458 mm X 303 mm X 310 mm
- c) 1 outer box = 12 (full tray) + 1 (dummy / top tray)

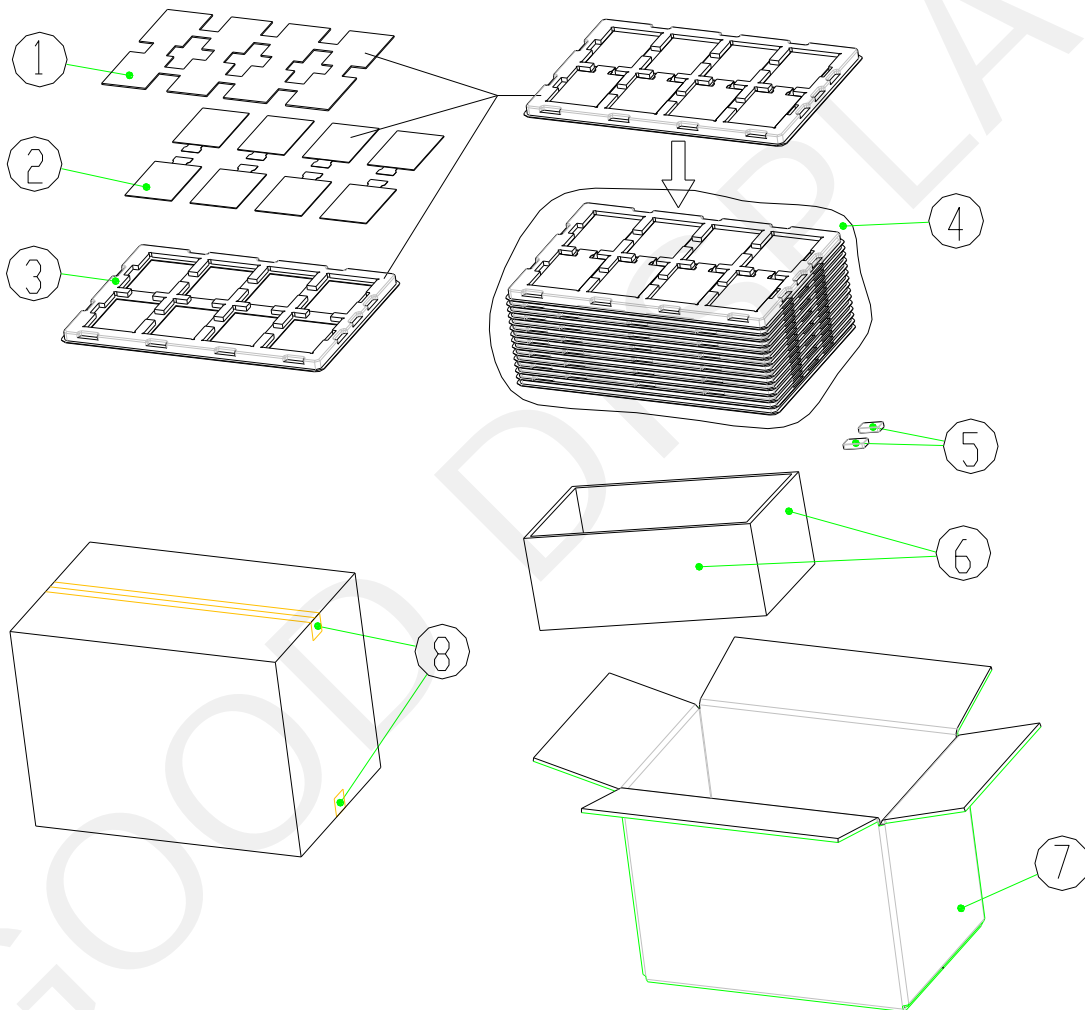

No.	Description	Material
①	PE Foam	EPE
②	Board Ass'y (96 pcs/1 Box)	EPD Panel
③	Packing, tray (13 pcs/1 outer box)	PS
④	Aluminium foil bag	Aluminium foil
⑤	Desiccant	Desiccant
⑥	side plate	EPE
⑦	Outer carton	K=A
⑧	Tape (43mm*300m)	OPP

13. Precautions

- (1) Do not apply pressure to the EPD panel in order to prevent damaging it.
- (2) Do not connect or disconnect the interface connector while the EPD panel is in operation.
- (3) Do not touch IC bonding area. It may scratch TFT lead or damage IC function.
- (4) Please be mindful of moisture to avoid its penetration into the EPD panel, which may cause damage during operation.
- (5) If the EPD Panel / Module is not refreshed every 24 hours, a phenomena known as "Ghosting" or "Image Sticking" may occur. It is recommended to refreshed the ESL / EPD Tag every 24 hours in use case. It is recommended that customer ships or stores the ESL / EPD Tag with a completely white image to avoid this issue
- (6) High temperature, high humidity, sunlight or fluorescent light may degrade the EPD panel's performance. Please do not expose the unprotected EPD panel to high temperature, high humidity, sunlight, or fluorescent for long periods of time.